

	A	B	C
TXT3	18.9	33.1	4.3
TXT4	18	36.8	5.4
TXT5	18.5	37.7	5.1
TXT6	22.5	44	6.1
TXT7	25.1	50	5.7
TXT8	30.1	60	5.2

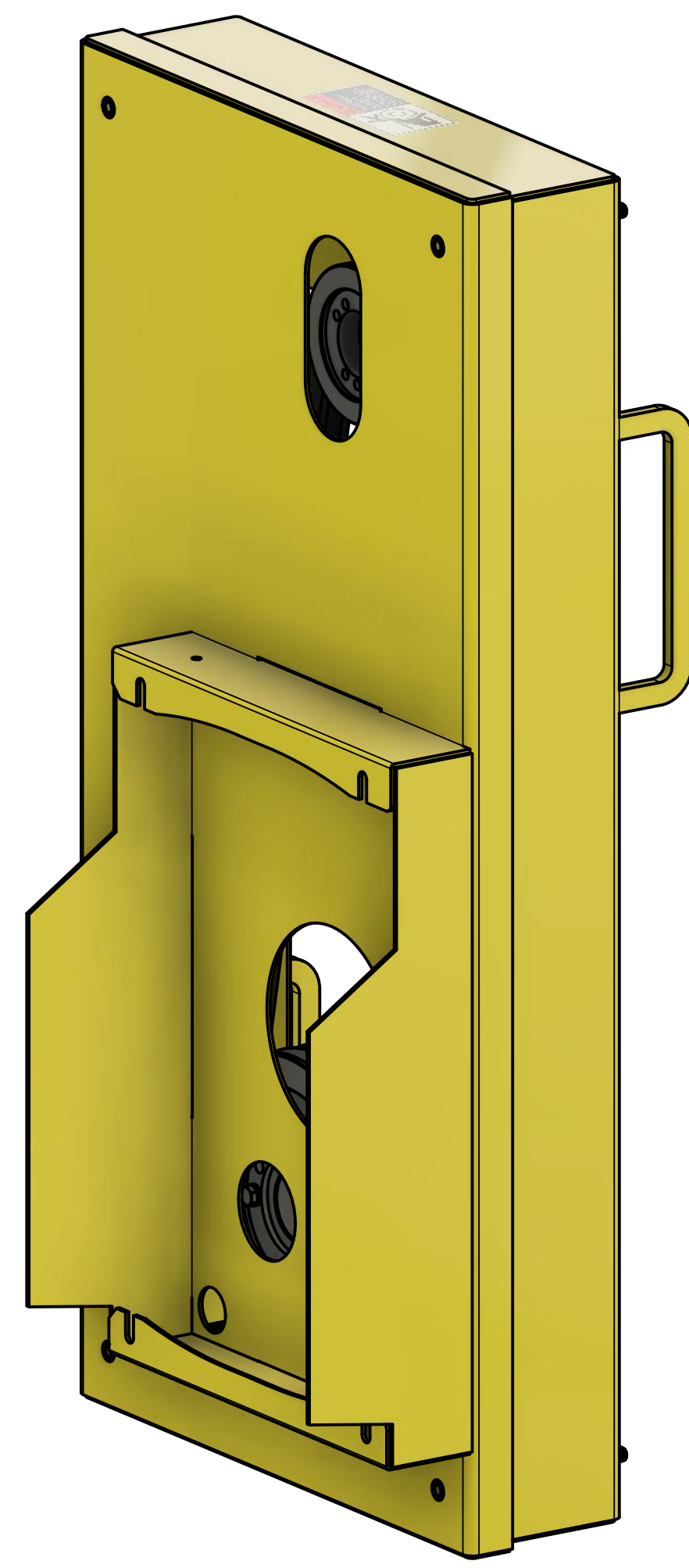

- HORIZONTAL AND VERTICAL POSITIONS AVAILABLE
- 12 GA CONSTRUCTION
- COMPLETE SHAFT GUARDING
- SMALLER FOOTPRINT
- BLACK EXPANDED METAL ON FRONT COVER OPENING & SAFETY YELLOW RAL 1018 INSIDE & OUT
- ALLOWS FOR STROBED LIGHTING (* MOBILE APP FOR ADJ FREQ STROBE) FOR MACHINE VISION USING PULSED LIGHT TO FREEZE MOTION FOR HIGH SPEED INSPECTION WHILE MACHINE IS IN SERVICE
- INSPECT SHEAVE V GROOVES WEAR AT BOTTOM OF V
- INSPECT BELTS FOR CRACKS, WEAR, OR PART NUMBER
- INSPECT SHEAVES FOR PART NUMBERS BUSHINGS

	PROJECT			REV
	GUARDS - FEEDERS			
TITLE		DWG NO		A1500
TXT COMPACT POSITION B		SCALE 1:8		
APPROVED	SIZE	CODE	WEIGHT	SHEET 1/4
CHECKED	D			
DRAWN	Ehsan Tootoonchi 2024-04-09			

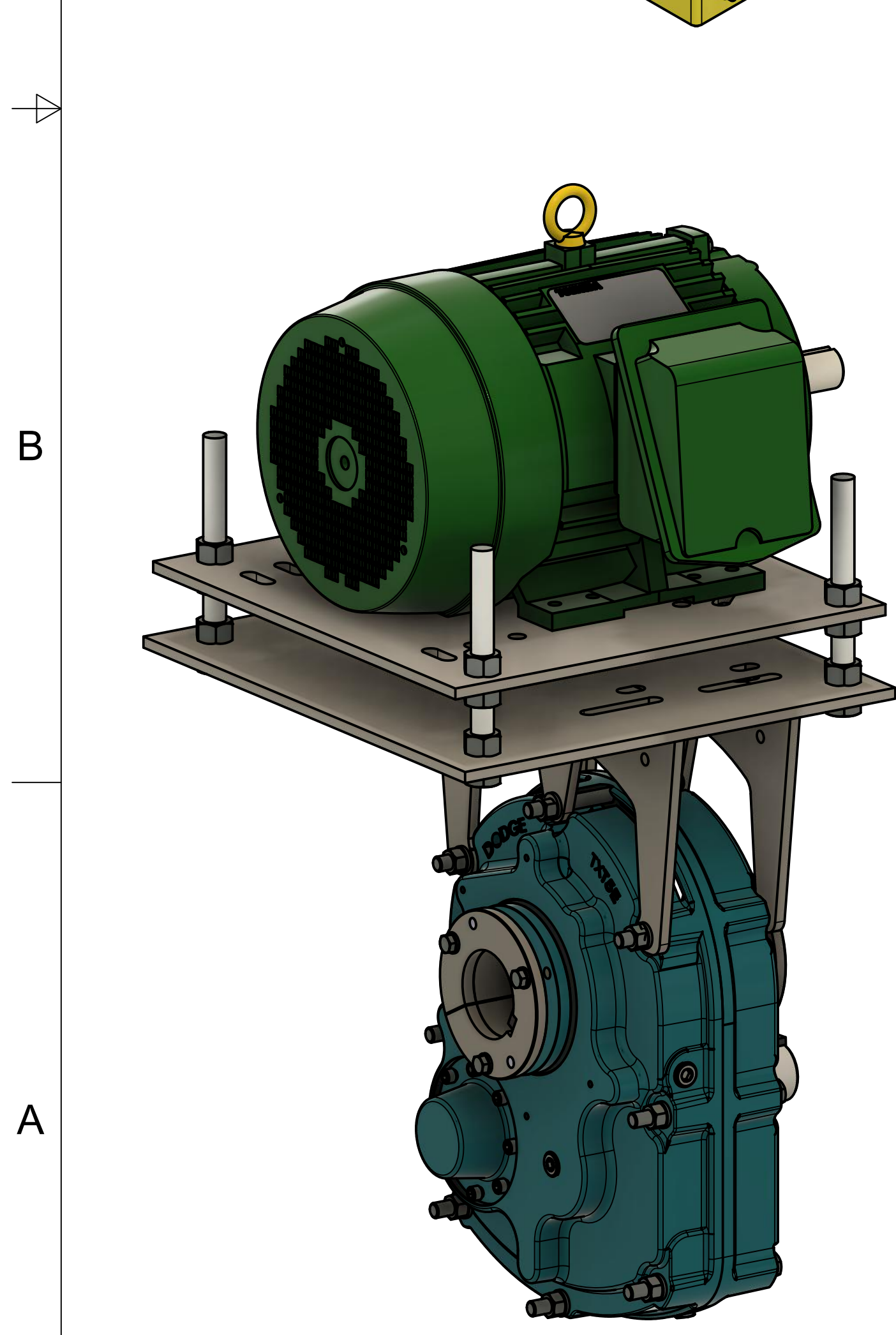
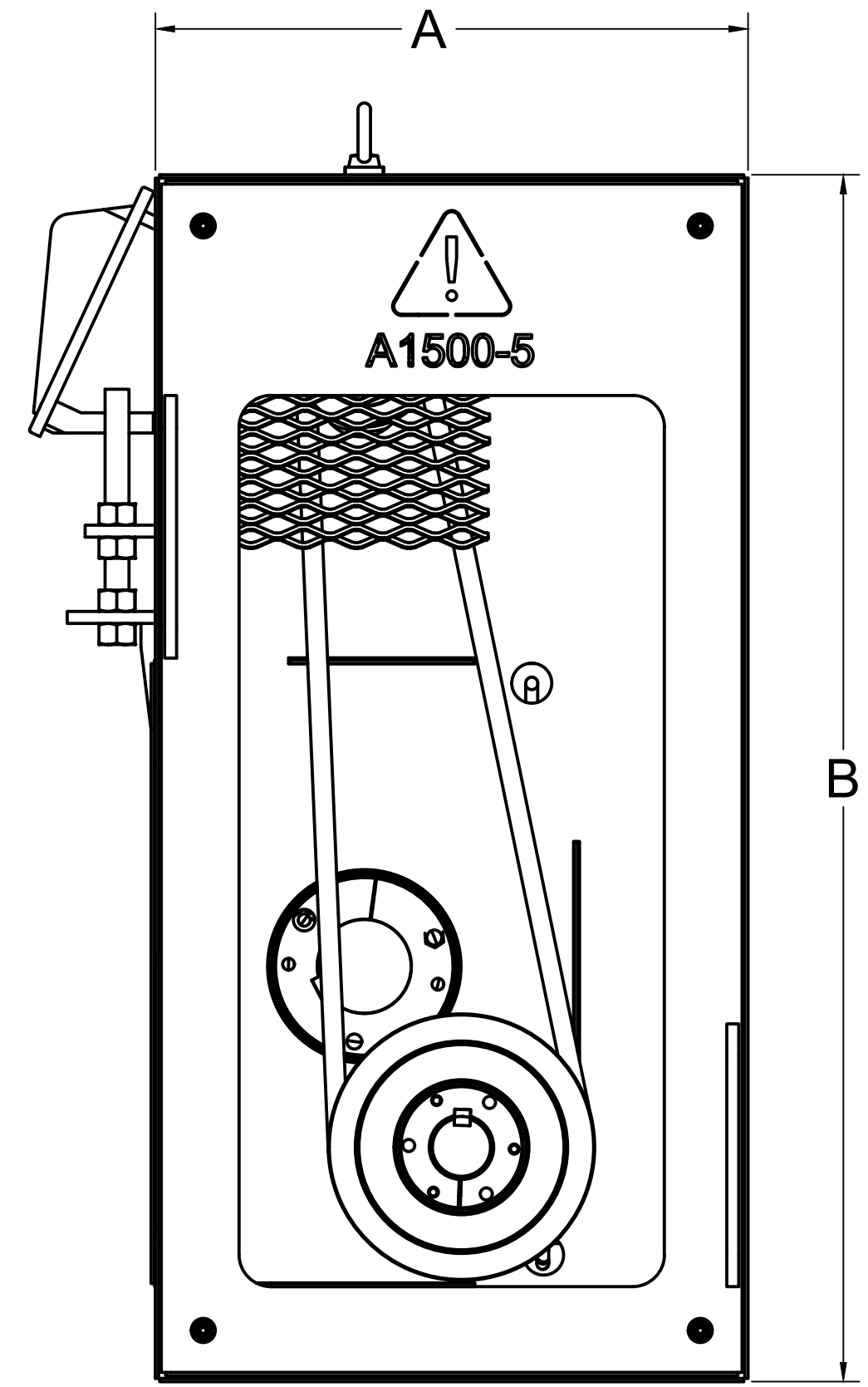
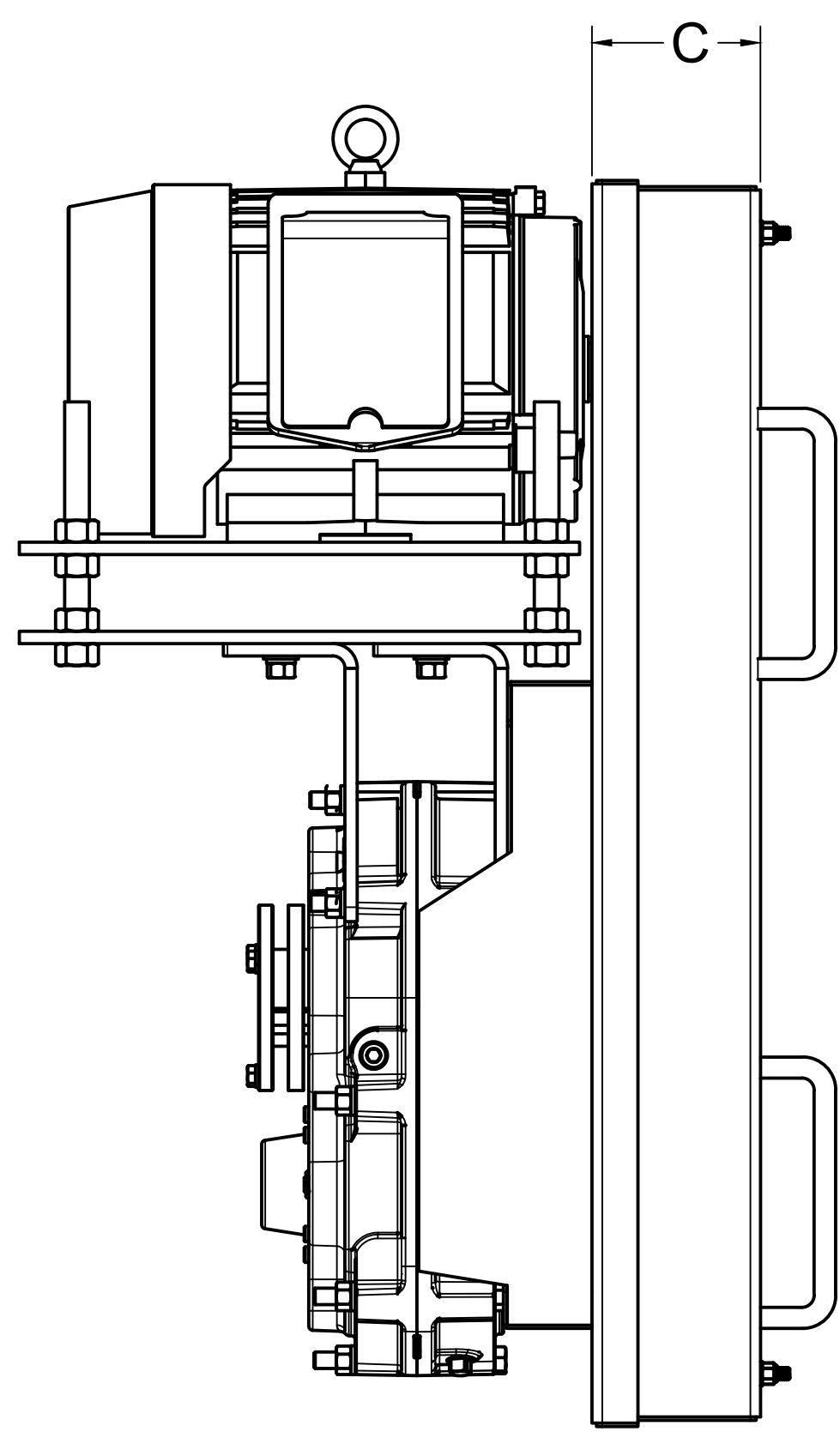
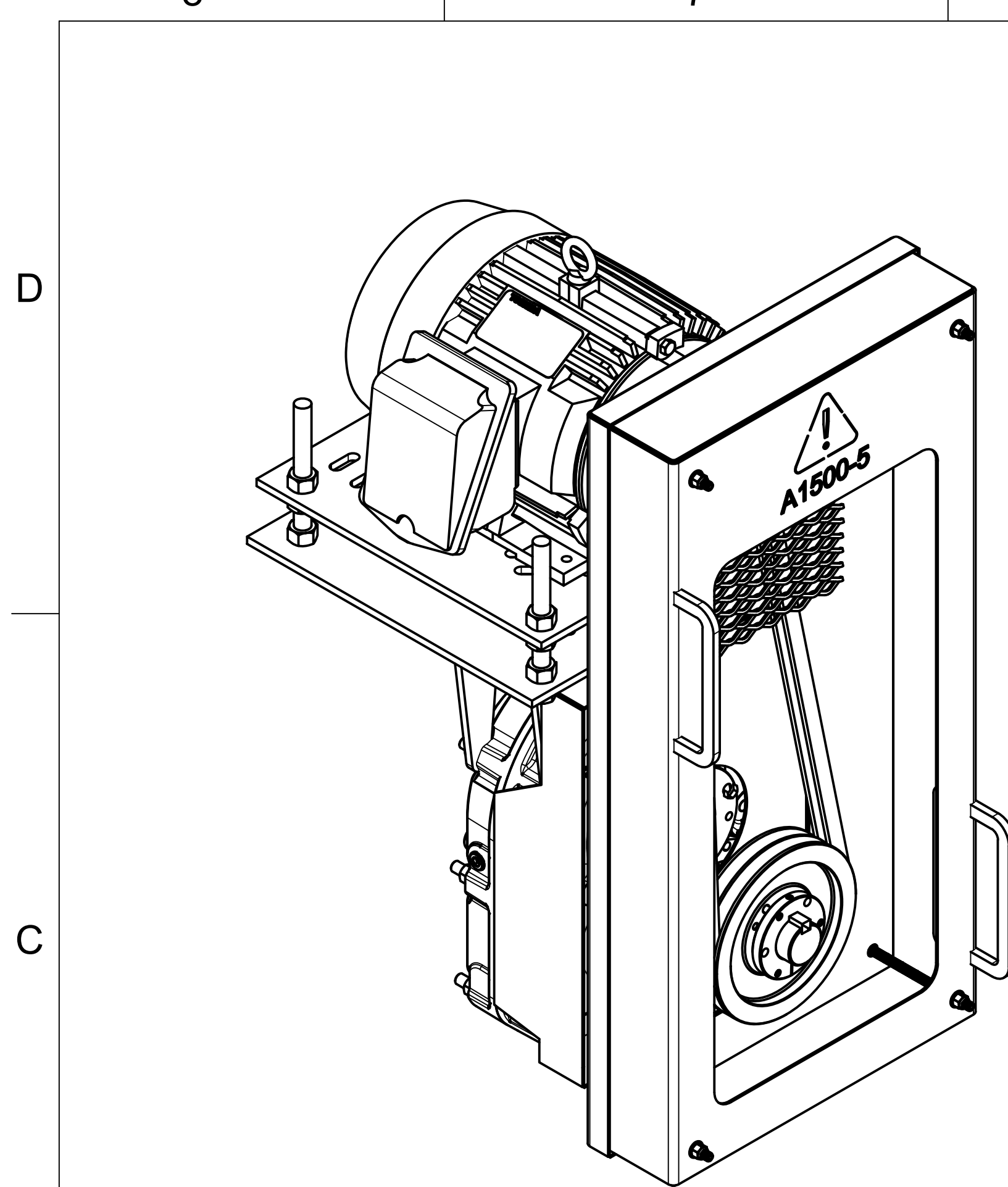

	A	B	C
TXT3	18.9	33.1	4.3
TXT4	18	36.8	5.4
TXT5	18.5	37.7	5.1
TXT6	22.5	44	6.1
TXT7	25.1	50	5.7
TXT8	30.1	60	5.2

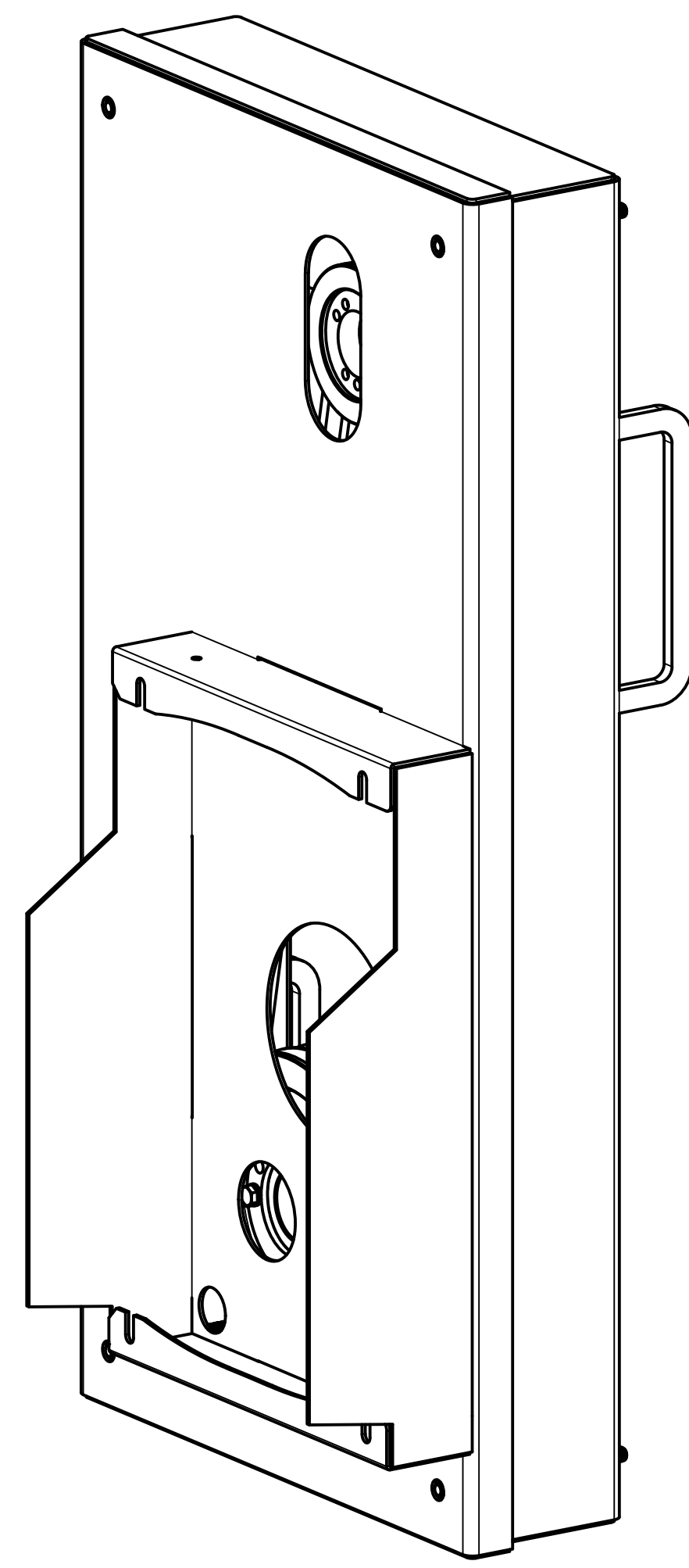
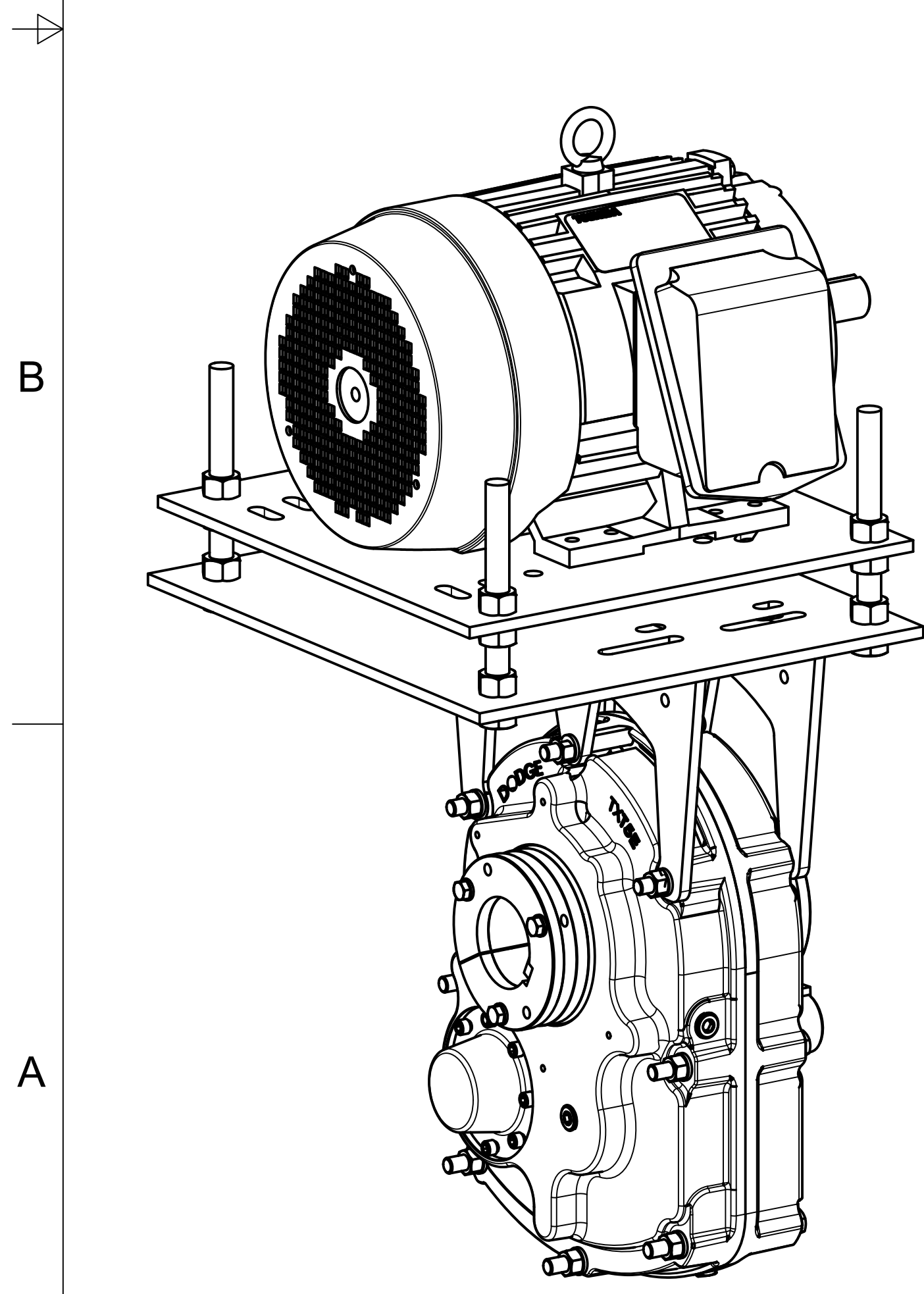

- HORIZONTAL AND VERTICAL POSITIONS AVAILABLE
- 12 GA CONSTRUCTION
- COMPLETE SHAFT GUARDING
- SMALLER FOOTPRINT
- BLACK EXPANDED METAL ON FRONT COVER OPENING AND SAFETY YELLOW RAL 1018 INSIDE AND OUT
- ALLOWS FOR STROBED LIGHTING (* MOBILE APP FOR ADJ FREQ STROBE) FOR MACHINE VISION USING PULSED LIGHT TO FREEZE MOTION FOR HIGH SPEED INSPECTION WHILE MACHINE IS IN SERVICE
- INSPECT SHEAVE V GROOVES WEAR AT BOTTOM OF VEE
- INSPECT BELTS FOR CRACKS, WEAR, PART NUMBER
- INSPECT SHEAVES FOR PART NUMBERS BUSHINGS

BAUM		PROJECT		GUARDS - FEEDERS	
		TITLE		TXT COMPACT POSITION B	
APPROVED	SIZE	CODE	DWG NO	A1500	REV
CHECKED	D				
DRAWN Ehsan Tootoonchi 2024-04-09		SCALE 1:8	WEIGHT	SHEET 2/4	