



WWW.BAUMPNEUMATICS.CA

Specifications

Isolators Drives and Capacities

A-1110

Rev. 5

8/20

FEEDER MODEL	BARE SHAFT WT	(TXT) ^Δ SHAFT MOUNT REDUCER	PREMIUM MOTOR H.P. + CLASS		FEEDER RPM		CAPACITY @100%		RECOMMENDED CAPACITIES - UPH	
			1	2	1 m/s LINEAR SPEED	BEARING TEMP SENSOR	DISPLACEMENT Cu.Ft. /Rev.	CFM	MAX UPH (70%)	FINE DUST (65%)
1418BE2F										
2025BE2F	1130	TXT425	3	5	34	34	3.7	125.5	26	24
2530BE2F										
2535BE2F	2290	TXT425	5	7.5	28	30	7.9	236.7	50	46
3035BE2F										
3045BE2F	4150	TXT625	10	15	24	28	14.6	407.8	86	80
3545BE2F	6000	TXT725	15	20	21	26	20.0	521.0	109	102
3555BE2F										

- Refer to the BAUM PNEUMATICS maintenance manual for safety and additional information regarding ESR / BE / ISOLATOR Feeders.
- For chip feeders see A-1105
- Firelocks are designed based on combustion characteristics of all fine SPF wood dust as per ASTM E1226 grinding specifications (see the Rotary valve passive isolation calculations report at BAUMPNEUMATICS.COM). Any change in material or size distribution requires new engineered design.
- Δ 1.68 service factor for belt drives
- High load of bigger particles would require a bigger clearance.

FEEDER SIZE IS DETERMINED BY DIAMETER X LENGTH OF HOUSING DISCHARGE

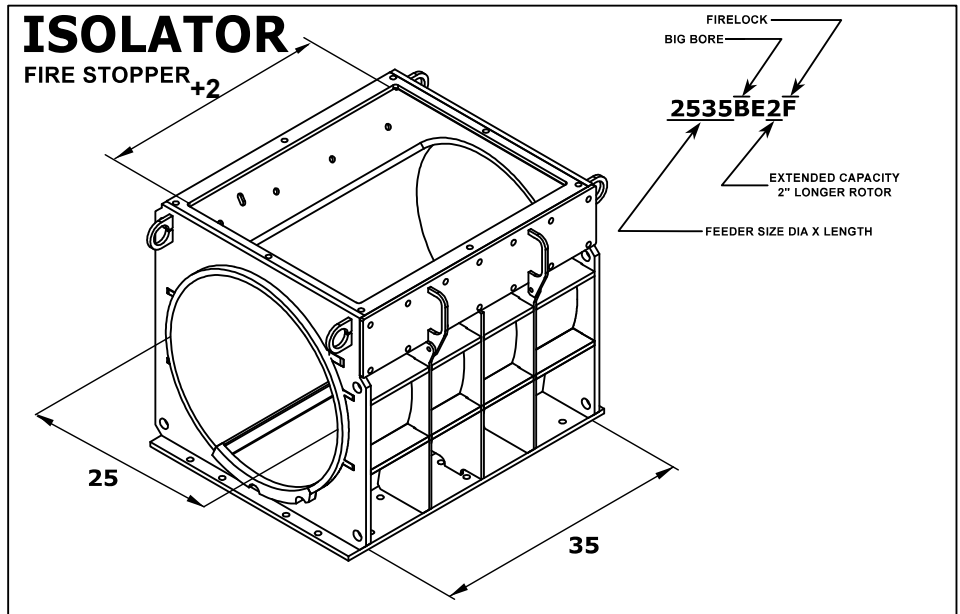

MAX volume (70%) can only be achieved with a good infeed (see A-1280).

UPH = Units Per Hour
one unit equals 200
cubic feet of loose material

Weight is in pounds (Net)

Reduce RPM for light material, (slower to reduce perculating the material at the infeed of the feeder)

+ Motor, Drive and Reducer is for **Class 2** Service.

Class 3 recommended for feeders operating close to their max capacity, (use 2 15/16 shaft on 20x30 feeder and 3 7/16 shaft on 25x35)